

Fairisle Yoke Pullover For Girls

Sizes 2-4-6-8-10-12, Finished Width 24-26-28-30-32-34 inches (61-66-71-76.5-81-86.5) cm
 Made on a Studio 360 punchcard machine with ribber, but suitable for any standard gauge model with punchcard or electronic pattern capability. If no ribber is available, bands may be hand knitted, or substitute mock ribbing.



Garment is shown in Child Size 4

Materials

Lightweight yarn, such as 4-ply, sock, fingering, or coned yarn equivalent, approximately 5-6-8-9-10 oz pink and 3 oz each white and fuchsia.

(Sample garment used pink for the sleeves and body, and white and fuchsia for the yoke. There is not much difference in value between the pink and white, and you could use pink throughout for the main color.)

Gauge: 28 sts, 40 rows = 10 cm, 7 stitches, 10 rows = inch in stockinet

Tension: approximately 7 for stockinet and 8 for Fairisle. This varies with different yarn and machines; always make a gauge swatch.

There are many ways machine knitters can make a round yoke garment. This pattern begins with the yoke, which is knitted in two identical pieces from bottom to top. After the yoke is completed, including finishing the two shoulder seams and adding the neckband, the back, front, and sleeves are picked up from the bottom of the yoke and knitted downwards.

This pattern has two body style options. For Option 1, the simpler version, back and front are the same, and traditional raglan seams are used below the yoke. This style usually fits children well, and is easier construction for those new to making round yoke garments.

Option 2 adds short row shaping just below the yoke on back, front, and sleeves for better fit. Short rows are worked at the same time as the raglan increases, and does require a little more concentration than option 1.

Yoke

Make 2 alike.

Set tension dial 1 full number higher (looser) than main stockinet setting. Cast on 104 (116-128-140-152-158) sts with waste yarn and ravel cord, ending with carriage on right. Insert punchcard and lock on row 1 of pattern.

Tier 1

RC 000. Change to white (main color) and knit 1 row, ending with carriage on left. Fasten a yarn marker on the strand of yarn between needle 1 left and needle 1 right of center 0 to **mark center of yoke**. Knit back to the right. Unlock pattern card.

Main color in feeder 1, contrast in feeder 2. Knit 11 rows in Fairisle, ending with carriage on left. RC 11. Remove contrast yarn; do not cut it; just hold it out of the way. Knit 1 row stockinet (this is the first unpunched row on the card, and the carriage will only knit main color on this row. Carriage is now on right. Advance card 1 row and lock (this is the first row of tier 2.) Remove main color but do not cut it. Remove on waste yarn.

Note: bring the needles forward slightly, NOT extended all the way

Tier 2

Take 7 (9-11-11-15-14) needles on each edge back to position A. Rehang yoke on 90 (98-106-118-122-130) remaining needles, as follows:

Size 2: Bring forward the 6th needle 14 times.

Size 4: Bring forward the 6th needle 2 times, the 5th needle 15 times, then the 6th needle 1 time.

Size 6: Bring forward the 5th needle 7 times, the 4th needle 8 times, then the 5th needle 7 times.

Size 8: Bring forward the 6th needle 2 times, the 5th needle 19 times, then the 6th needle 1 time.

Size 10: Bring forward the 4th needle 15 times, the 3rd needle 1 time, then the 4th needle 14 times

Size 12: Bring forward the 5th needle 7 times, the 4th needle 14 times, then the 5th needle 7 times.

Pick up 2 stitches onto each extended needle, 1 stitch onto the others.

Replace main color and knit 1 row, ending with carriage on left.

RC 000. Unlock pattern card. Replace contrast yarn in feeder 2, and work 11 rows Fairisle (note that rows 3 and 4 are main color only; remove contrast yarn after knitting row 2, and put it back in the carriage after row 4.)

RC 11. Remove contrast yarn but do not cut it. Knit 1 row stockinet, ending with carriage on left. Advance card 1 row and lock (this is the first row of tier 3.) Remove main color but do not cut it. Remove on waste yarn.

Tier 3, Sizes 2-4-6 Only

Take 5 (6-7-10-12-13) needles on each edge back to position A. Rehang yoke on 80 (86-92-98-98-104) remaining needles, as follows:

Size 2: Bring forward the 8th needle 2 times, the 7th needle 7 times, then the 8th needle 1 time.

RC 000. Replace contrast yarn in feeder 2, and work 11 rows Fairisle (note that rows 3 and 4 are main color only; remove contrast yarn after knitting row 2, and put it back in the carriage after row 4.)

RC 11. Cut contrast yarn. Knit 1 row stockinet with main color.

Decrease for top edge: Bring forward the 4th needle 1 time, the 3rd needle 23 times, then the 4th needle 1 time; transfer these stitches to a neighboring needle. **55 stitches remain.** Knit 1 row main color, then remove on waste yarn.

Size 4: Bring forward the 7th needle 4 times, the 6th needle 4 times, then the 7th needle 4 times. RC 000. Replace contrast yarn in feeder 2, and work 11 rows Fairisle (note that rows 3 and 4 are main color only; remove contrast yarn after knitting row 2, and put it back in the carriage after row 4.)

RC 11. Cut contrast yarn. Knit 1 row stockinet with main color.

Decrease for top edge: Bring forward the 3rd needle 13 times, the 2nd needle 3 times, then the 3rd needle 13 times, transfer these stitches to a neighboring needle. **57 stitches remain.** Knit 1 row main color, then remove on waste yarn.

Size 6: Bring forward the 7th needle 1 time, the 6th needle 12 times, then the 7th needle 1 time. RC 000. Replace contrast yarn in feeder 2, and work 11 rows Fairisle (note that rows 3 and 4 are main color only; remove contrast yarn after knitting row 2, and put it back in the carriage after row 4.)

RC 11. Cut contrast yarn. Knit 1 row stockinet with main color.

Decrease for top edge: Bring forward the 3rd needle 12 times, the 2nd needle 9 times, then the 3rd needle 12 times, transfer these stitches to a neighboring needle. **59 stitches remain.** Knit 1 row main color, then remove on waste yarn.

Tier 3, Sizes 8-10-12 Only

Size 8: Bring forward the 9th needle 10 times.

Size 10: Bring forward the 4th needle 12 times, the 3rd needle 1 times, then the 4th needle 11 times.

Size 12: Bring forward the 4th needle 12 times, the 3rd needle 3 times, then the 4th needle 11 times.

Pick up 2 stitches onto each extended needle, 1 stitch onto the others.
Replace main color and knit 1 row, ending with carriage on left.

RC 000. Replace contrast yarn in feeder 2, and work 11 rows Fairisle (note that rows 3 and 4 are main color only; remove contrast yarn after knitting row 2, and put it back in the carriage after row 4.)

Tier 4 Sizes 8-10-12 Only

Take 9 (9-9) needles on each edge back to position A. Rehang yoke on 80 (80-86) remaining needles, as follows, picking up 2 stitches on each forward needle.

Size 8: Bring forward the 5th needle 2 times, the 4th needle 14 times, then the 5th needle 2 times. Knit 5 rows with main color only. Do not remove on waste yarn.

Decrease for top edge: Bring forward the 4th needle 3 times, the 3rd needle 13 times, then the 4th needle 2 times. Transfer these stitches to a neighboring needle. Return emptied needles to pos A. **62 stitches remain.** Knit 1 row main color, then remove on waste yarn.

Size 10: Bring forward the 5th needle 2 times, the 4th needle 14 times, then the 5th needle 2 times. Knit 9 rows with main color only. Do not remove on waste yarn.

Decrease for top edge: Bring forward the 4th needle 3 times, the 3rd needle 13 times, then the 4th needle 2 times. Transfer these stitches to a neighboring needle. Return emptied needles to pos A. **62 stitches remain.** Knit 1 row main color, then remove on waste yarn.

Size 12: Bring forward the 5th needle 2 times, the 4th needle 14 times, then the 5th needle 2 times. Knit 9 rows with main color only. Do not remove on waste yarn.

Decrease for top edge: Bring forward the 4th needle 9 times, the 3rd needle 5 times, then the 4th needle 8 times. Transfer these stitches to a neighboring needle. Return emptied needles to pos A. **64 stitches remain.** Knit 1 row main color, then remove on waste yarn.

Knit another yoke section the same. Blocking is recommended at this point; it makes it easier to sew the shoulder seams. Sew one seam.

Neckband

Rehang top of yoke on the machine. With seam at center 0, pick up every stitch held by waste yarn. Pick up the stitch in the seam allowance on each side also; it is a live stitch and will run if not secured. Hang these seam stitches on needles 1 left and 1 right of center 0. 108 (112-116-118-122) stitches. Transfer every other stitch to ribber.

Set stitch dials 2 numbers lower (tighter) than used for Fairisle yoke.

RC 000. Knit 12 rows for single band, or 24 rows for doubled band. Bind off loosely; this must stretch to go over the head.

Sew remaining yoke seam.

If using a doubled neckband, turn down to the inside and sew loosely to first row of band, again remembering that this must have enough stretch to go over the head.

Alternate Neckband Method

Cast on 108 (112-116-118-122) stitches in ribbing.

Work 23 rows with stitch dials 2 numbers tighter than Fairisle yoke. Transfer stitches to main bed, and set stitch dial to Fairisle tension. Knit 1 row and remove on waste yarn.

Rehang yoke, with knit side facing you, purl side toward the machine. (This should be the same number of stitches as the band.) Bring the needles forward about half way, until these stitches slide back behind the latches.

Rehang the neckband into the hooks of the same needles, then push them back through the yoke stitches, so that only one stitch remains on each needle.

Pick up the cast on edge of the neckband, and hang into corresponding needle hooks. (2 stitches are now on each needle.)

Bind off loosely. Backstitch bind off will work, or bind off around the gate pegs with the latch tool.

Remove work from the machine by lifting up carefully out of the needle hooks, or off the gatepegs.

Sew remaining yoke seam.

Body and Sleeves

Back, front, and sleeves are picked up from the cast on edge of the yoke and worked downwards.

Note: the total of back or front plus sleeves is not the same as the cast on edge of a yoke panel.

Because of the way knitting stitches are formed, there is one less stitch when picking up from the waste yarn and knitting downwards. 2 more stitches are also used for yoke seams. Therefore, **there are 3 more stitches in a yoke panel** than the total of back/front plus sleeves.

Option 1. Back and Front, Simple Shaping (make 2 alike)

Hold bottom edge of yoke with knit side toward the machine, purl side facing you. Begin with the yarn marker on the bottom of the yoke. Place this stitch on needle 1 right of center 0, then pick up a total of 65 (71-77-81-87-91) stitches, from 32 (35-38-40-43-45) left of center 0 to 33 (36-39-41-44-46) right of 0.

Shape Raglan Armholes

RC 000. Set stitch dial to main tension.

Increase 1 stitch both sides, using the 2-prong transfer tool; this creates seam stitches. Thread carriage with main color and fasten a clip on the yarn end to hold it down out of the way. Knit 2 rows.

RC 2. Increase 1 stitch both sides on this and every following 2nd row a total of 3 (4-5-6-7-8) more times, ending on RC 8 (10-12-14-16-18) with 73 (81-89-95-103-109) stitches.

Cast on 6 (6-6-5-5-5) stitches at the beginning of the next 2 rows, ending with 85 (93-101-105-113-119) stitches.

Go to Lower Body instructions.

Lower Body

Reset RC to 000. Knit even to RC 76 (80-90-100-116-122). Lengthen or shorten here as desired; be sure to make a note of how many rows were added or subtracted.

Ribbing

Transfer every other stitch to the ribber.

Tighten stitch dials 2 numbers lower than stockinet setting and knit 12 rows.

Turn stitch dials as high as they will go and knit 1 row.

Bind off using stitch through stitch method.

Make other Back/Front the same.

Sleeves, Simple Shaping (make 2 alike)

Hold bottom edge of yoke with knit side toward the machine, purl side facing you. **Shoulder seam goes at center 0.** Pick up 36 (42-48-56-62-64) stitches, from 18 (21-24-28-31-32) left of center 0 to 18 (21-24-28-31-32) right of 0. This should be every remaining stitch that is held by waste yarn and ravel cord between a back body section and a front body section. Thread carriage with main color and fasten a clip on the end to hold it down out of the way

Shape Raglan Armholes

RC 000. Set stitch dial to main tension.

Increase 1 stitch both sides, using the 2-prong transfer tool; this creates seam stitches. Thread carriage with main color and fasten a clip on the yarn end to hold it down out of the way. Knit 2 rows.

RC 2. Increase 1 stitch both sides on this and every following 2nd row a total of 3 (4-5-6-7-8) more times, ending on RC 8 (10-12-14-16-18) with 44 (52-60-70-78-82) stitches.

Cast on 6 (6-6-5-5-5) stitches at the beginning of the next 2 rows, ending with 56 (64-72-80-88-92) stitches.

Go to Lower Sleeve instructions.

Lower Sleeve

Reset RC to 000.

Size 2: Decrease 1 stitch both sides every 13 rows 4 times, then every 12 rows 1 time. Knit even to RC 75 on remaining 46 stitches.

Decrease 5 stitches evenly, as follows: pull forward the 8th needle 4 times, then the 7th needle 1 time; transfer these stitches to a neighboring needle. **41 stitches remain.** Knit 1 row. Remove these stitches on waste yarn.

Size 4: Decrease 1 stitch both sides every 12 rows 2 times, then every 11 rows 5 times. Knit even to RC 89 on remaining 50 stitches.

Decrease 7 stitches evenly, as follows: pull forward the 7th needle 1 time, the 6th needle 5 times, then the 7th needle 1 time; transfer these stitches to a neighboring needle. **43 stitches remain.** Knit 1 row. Remove these stitches on waste yarn.

Size 6: Decrease 1 stitch both sides every 10 rows 9 times. Knit even to RC 99 on remaining 54 stitches. Decrease 9 stitches evenly, as follows: pull forward the 6th needle 2 times, the 5th needle 5 times, then the 6th needle 2 times; transfer these stitches to a neighboring needle. Knit 1 row. **45 stitches remain.** Remove these stitches on waste yarn.

8: Decrease 1 stitch both sides every 9 rows 6 times, then every 8 rows 6 times. Knit even to RC 109 on remaining 56 stitches. Decrease 9 stitches evenly, as follows: pull forward the 6th needle 3 times, the 5th needle 3 times, then the 6th needle 3 times; transfer these stitches to a neighboring needle. **47 stitches remain.** Knit 1 row. Remove these stitches on waste yarn.

Size 10: Decrease 1 stitch both sides every 8 rows 15 times. Knit even to RC 125 on remaining 58 stitches. Decrease 9 stitches evenly, as follows: pull forward the 6th needle 9 times; transfer these stitches to a neighboring needle. **49 stitches remain.** Knit 1 row. Remove these stitches on waste yarn.

Size 12: Decrease 1 stitch both sides every 9 rows 10 times, then every 8 rows 6 times. Knit even to RC 145 on remaining 60 stitches. Decrease 9 stitches evenly, as follows: pull forward the 6th needle 9 times; transfer these stitches to a neighboring needle. **51 stitches remain.** Knit 1 row. Remove these stitches on waste yarn.

Cuff

Rehang 41 (43-45-47-49-51) stitches, then transfer every other stitch to the ribber. Work 26 rows ribbing at 2 numbers tighter than main tension. Turn stitch dials up as far as they will go, knit 1 row, and bind off using stitch through stitch method.

Finishing

Sew side and sleeve seams. Work in yarn ends. Block if desired.

Option 2. Body and Sleeves Shaped With Short Rows Below The Yoke**Back**

Hold bottom edge of yoke with knit side toward the machine, purl side facing you. Begin with the yarn marker on the bottom of the yoke. Place this stitch on needle 1 right of center 0, then pick up a total of 65 (71-77-81-87-91) stitches, from 32 (35-38-40-43-45) left of center 0 to 33 (36-39-41-44-46) right of 0.

Shape Raglan Armholes

Begin with carriage on left side of bed. Place all stitches into hold position, and set carriage to hold.

Work short rows on left side only.

Thread carriage with main color and fasten a clip on the yarn end to hold it down out of the way. RC 000. Stitch dial 7. Return first 5 stitches to work position. Increase 1 stitch on left edge using the 2-prong transfer tool; this creates a seam stitch. Knit to the right, wrap first HP needle, knit back to left. (KWK) 6 sts in work on left.

RC 2. Return next 5 sts to work, inc 1 st on left. KWK. 12 sts in work on left.

RC 4. Return next 5 sts to work, inc 1 st on left. KWK. 18 sts are now in work on left.

This completes the left short row shaping; cancel hold on carriage and knit 1 row to the right. Return all stitches to hold position, and set carriage to hold.

Work short rows on right side only.

RC 000. Return first 5 stitches to work position. Increase 1 stitch on right edge using the 2-prong transfer tool to create a seam stitch. Knit to the left, wrap first HP needle, knit back to right. (KWK) 6 sts in work on right.

RC 2. Return next 5 sts to work, inc 1 st on right. KWK. 12 sts in work on right.

RC 4. Return next 5 sts to work, inc 1 st on right. KWK. 18 sts are now in work on right.

This completes the short row shaping. Cancel hold setting on carriage.

RC 6. Increase 1 stitch both sides on this and every following 2nd row a total of 1 (2-3-4-5-6) more times, ending on RC 8 (10-12-14-16-18) with 73 (81-89-95-103-109) stitches.

Cast on 6 (6-6-5-5-5) stitches at the beginning of the next 2 rows, ending with 85 (93-101-105-113-119) stitches.

Go to Lower Body instructions, above.

Front

Hold bottom edge of yoke with knit side toward the machine, purl side facing you. Begin with the yarn marker on the bottom of the yoke. Place this stitch on needle 1 right of center 0, then pick up a total of 65 (71-77-81-87-91) stitches, from 32 (35-38-40-43-45) left of center 0 to 33 (36-39-41-44-46) right of 0.

For sizes 2 and 4 only, work Front exactly the same as Back. For sizes 6-8-10-12, work as follows:

Shape Raglan Armholes

Begin with carriage on left side of bed. Place all stitches into hold position, and set carriage to hold.

Work short rows on left side only.

Thread carriage with main color and fasten a clip on the yarn end to hold it down out of the way. RC 000. Stitch dial 7. Return first 5 stitches to work position. Increase 1 stitch on left edge using the 2-prong transfer tool; this creates a seam stitch. Knit to the right, wrap first HP needle, knit back to left. (KWK) 6 sts in work on left.

RC 2. Return next 5 sts to work, inc 1 st on left. KWK. 12 sts in work on left.

RC 4. Return next 5 sts to work, inc 1 st on left. KWK. 18 sts are now in work on left.

RC 6. Return next 5 sts to work, inc 1 st on left. KWK. 24 sts are now in work on left.

RC 8. Return next 5 sts to work, inc 1 st on left. KWK. 30 sts needles 39 L through 10 L, are now in work on left.

This completes the left short row shaping; cancel hold on carriage and knit 1 row to the right. Return all stitches to hold position, and set carriage to hold.

Work short rows on right side only.

RC 000. Return first 5 stitches to work position. Increase 1 stitch on right edge using the 2-prong transfer tool to create a seam stitch. Knit to the left, wrap first HP needle, knit back to right. (KWK) 6 sts in work on right.

RC 2. Return next 5 sts to work, inc 1 st on right. KWK. 12 sts in work on right.

RC 4. Return next 5 sts to work, inc 1 st on right. KWK. 18 sts are now in work on right

This completes the short row shaping. Cancel hold setting on carriage.

RC 6. Return next 5 sts to work, inc 1 st on left. KWK. 24 sts are now in work on right.

RC 8. Return next 5 sts to work, inc 1 st on left. KWK. 30 sts are now in work on right.

RC 10. Return next 5 sts to work, inc 1 st on left. KWK. 36 sts are now in work on right.

RC 12. Increase 1 stitch both sides on this and every following 2nd row a total of 0 (1-2-3) more times, ending on RC 12 (14-16-18) with 89 (95-103-109) stitches.

Cast on 6 (5-5-5) stitches at the beginning of the next 2 rows, ending with 101 (105-113-119) stitches.

Go to Lower Body instructions, above.

Sleeves

Hold bottom edge of yoke with knit side toward the machine, purl side facing you. ***Shoulder seam goes at center 0.*** Pick up 36 (42-48-56-62-64) stitches, from 18 (21-23-28-31-32) left of

center 0 to 18 (21-23-28-31-32) right of 0. This should be every remaining stitch that is held by waste yarn and ravel cord between a back body section and a front body section.

Shape Raglan Armholes

Begin with carriage on left side of bed. Place all stitches into hold position, and set carriage to hold.

Work short rows on left side only.

Thread carriage with main color and fasten a clip on the yarn end to hold it down out of the way. RC 000. Stitch dial 7. Return first 5 stitches to work position. Increase 1 stitch on left edge using the 2-prong transfer tool; this creates a seam stitch. Knit to the right, wrap first HP needle, knit back to left. (KWK) 6 sts in work on left.

RC 2. Return next 5 sts to work, inc 1 st on left. KWK. 12 sts in work on left.

RC 4. Return next 5 sts to work, inc 1 st on left. KWK. 18 sts are now in work.

This completes the left short row shaping; cancel hold on carriage and knit 1 row to the right. Return all stitches to hold position, and set carriage to hold.

Work short rows on right side only.

RC 000. Return first 5 stitches to work position. Increase 1 stitch on right edge using the 2-prong transfer tool to create a seam stitch. Knit to the left, wrap first HP needle, knit back to right. (KWK) 6 sts in work on right.

RC 2. Return next 5 sts to work, inc 1 st on right. KWK. 12 sts in work on right.

RC 4. Return next 5 sts to work, inc 1 st on right. KWK. 18 sts are now in work.

This completes the short row shaping. Cancel hold setting on carriage.

RC 6. Increase 1 stitch both sides on this and every following 2nd row a total of 1 (2-3-4-5-6) more times, ending on RC 8 (10-12-14-16-18) with 44 (52-58-70-78-82) stitches.

Cast on 6 (6-6-5-5-5) stitches at the beginning of the next 2 rows, ending with 56 (64-70-80-88-92) stitches.

Go to Lower Body instructions, above.

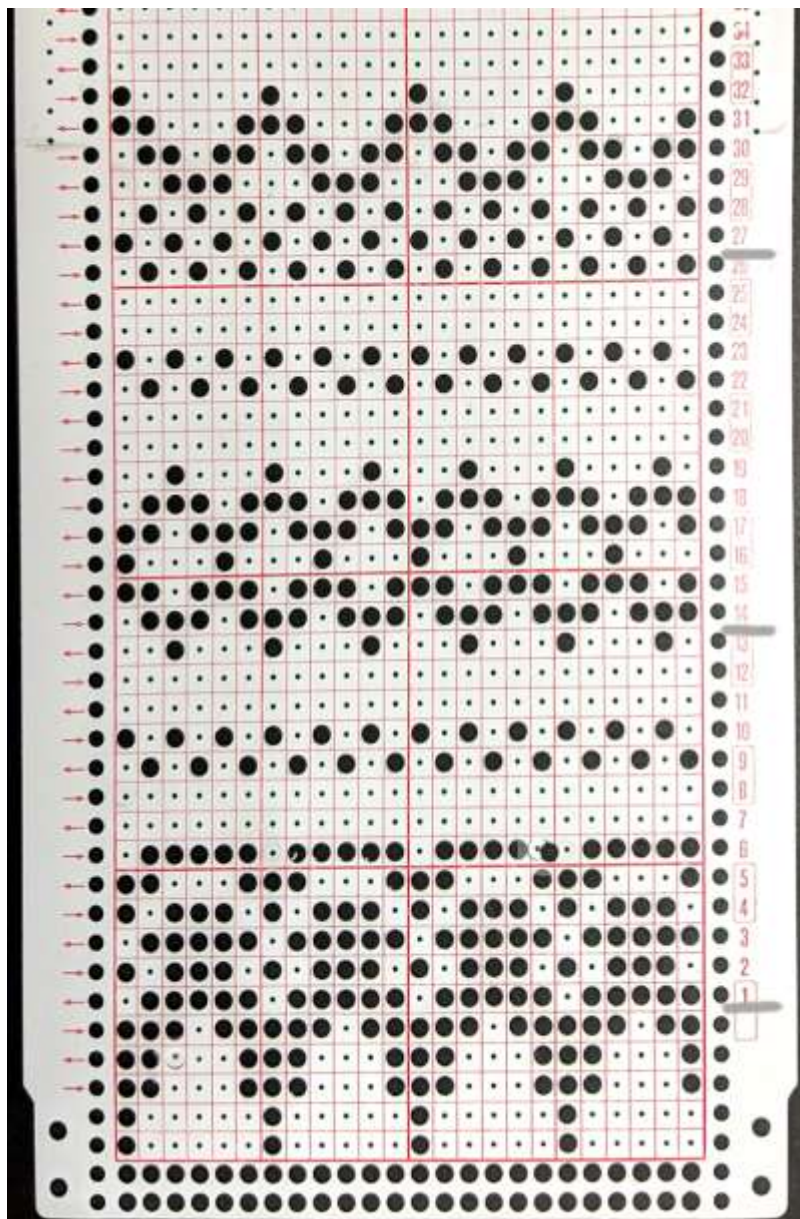

The pencil marks on the side of the punchcard indicate which row is visible above the card slot for the first row of each tier. *This is a Studio card and is marked for Studio/Silver Reed machines. If using it on a Brother machine, place marks 2 rows higher.*

Abbreviations

RC = row count. This is the number showing in the row counter window.

KWK = knit, wrap, knit. This is used when short rowing, in order to prevent a hole. It is worked as follows:

Method 1: place required stitches into hold position, knit 1 row; pass yarn under first holding needle, and knit back to the original side.

Method 2 (automatic wrap method): place required stitches, minus 1, into hold position, knit 1 row; bring the last required stitch also to hold, knit back to original side.

Measurement on this schematic are in inches.

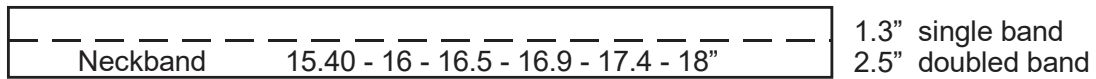

NOTE: Tier 4 for is for sizes 8 - 10 -12 only
 Tier 4 10.6 - 11.4 - 12.3" .6 - 1"

Tier 3 11.4 - 12.3 - 13.2 - 13.4 - 13.8 - 14" 1.3"

Tier 2 13 - 14 - 15 - 16.6 - 17.4 - 18.3" 1.5"

Tier 1 14.8 - 16.6 - 18.3 - 20 - 21.8 - 22.6" 1.5"

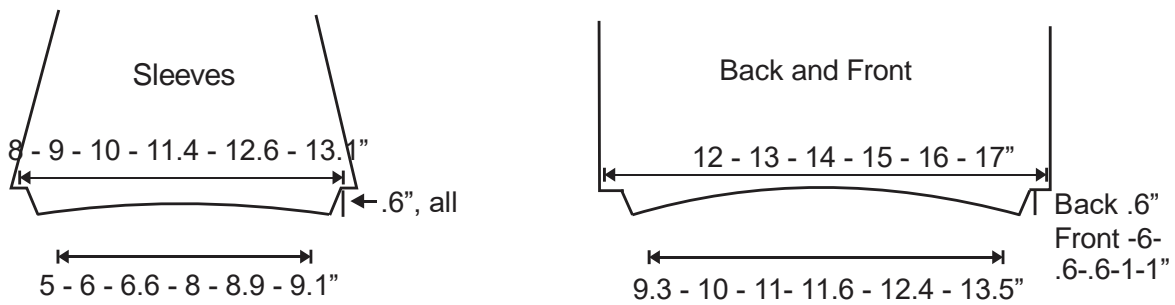
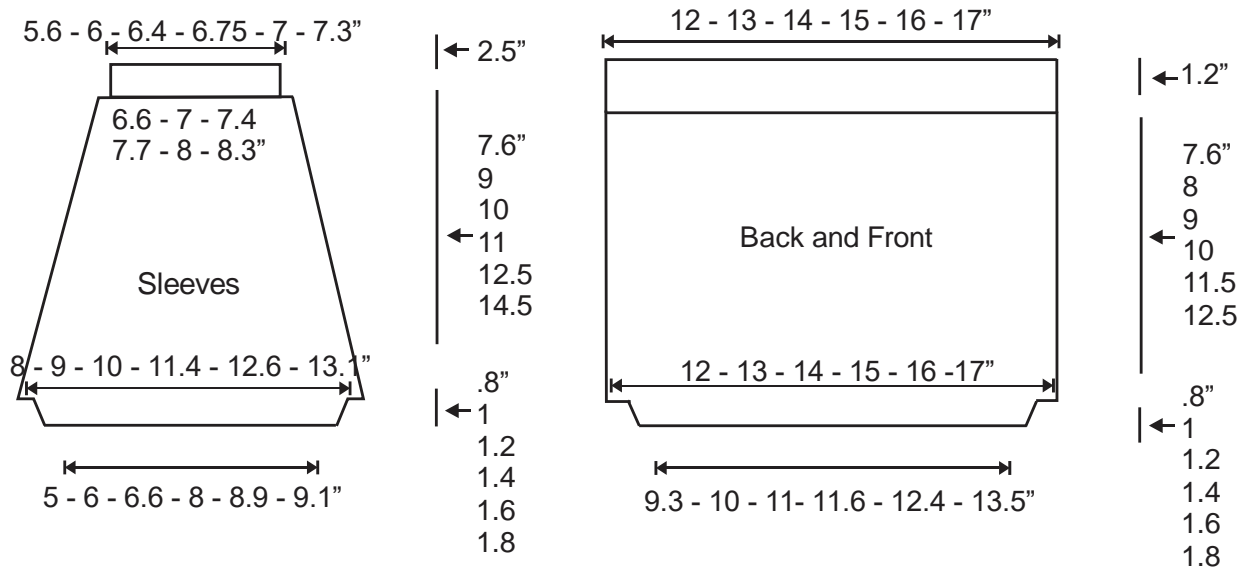

Optional short row shaping on Sleeves, Back and Front

Measurements on this schematic are in centimeters.

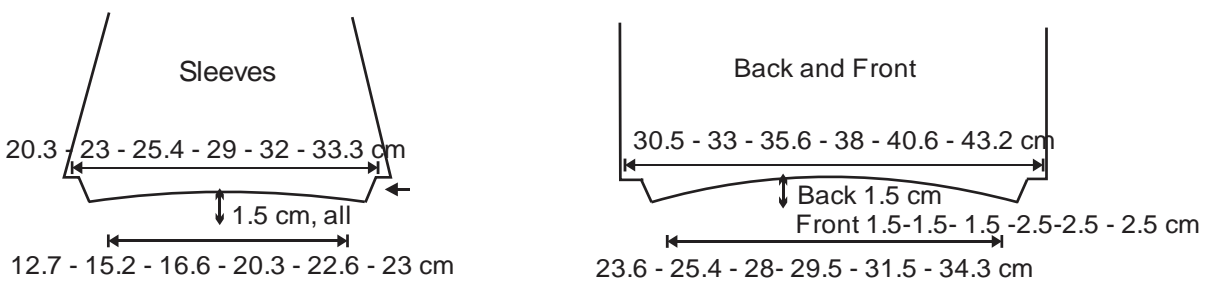
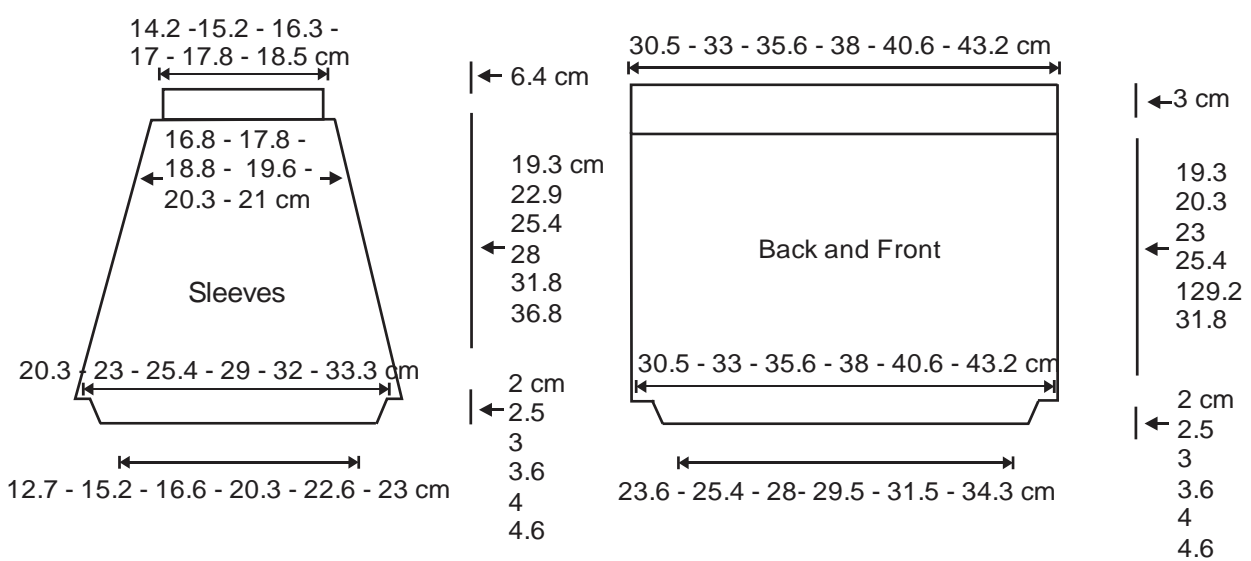
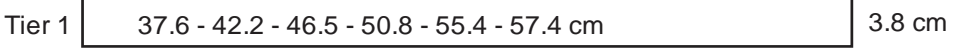
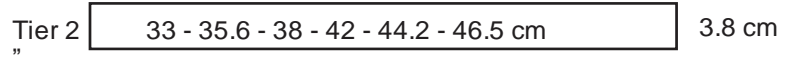
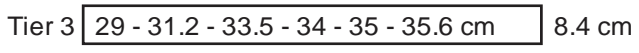
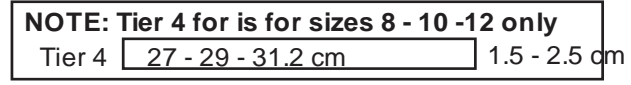
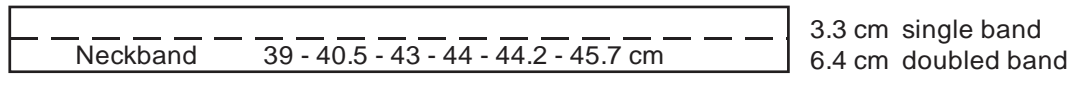

Optional short row shaping on Sleeves, Back and Front